



PROFILE OF INNOVATION



Schluter®-KERDI-BOARD

Substrate, building panel, bonded waterproofing





Schluter®-KERDI-BOARD

The universal substrate for tiles

Flat. Level. Plumb. Square.

Whether you work with mosaics or large-format tiles, an absolutely flat substrate with straight and precisely aligned inside and outside corners is essential for creating a perfect tile covering. Tile setters can now achieve flat, level, plumb, and square substrates with Schluter®-KERDI-BOARD.

Schluter®-KERDI-BOARD gives tile setters more control over their projects by providing them with the means to simply and easily create ideal substrates for tile. Unsuitable substrates can be remedied and new substrates can be created while keeping the technical and aesthetic requirements of the tile covering in mind.

For this purpose, Schluter®-KERDI-BOARD offers the following properties:

- Even, impact-resistant, and rigid
- Waterproof, temperature-resistant, and dimensionally stable
- Vapor-retardant
- Thermally insulating
- Fleece webbing for easy anchoring in thin-set mortar
- Quick and easy to install
- Lightweight, easy to handle and transport
- Contains no cement or fiberglass
- Dust-free and easy to cut (with a utility knife)
- Printed gridlines for precise cutting
- Suitable for use on any kind of structure
- Suitable for bathtub platforms, freestanding partition walls, vanities, storage shelves, countertops, and various other elements

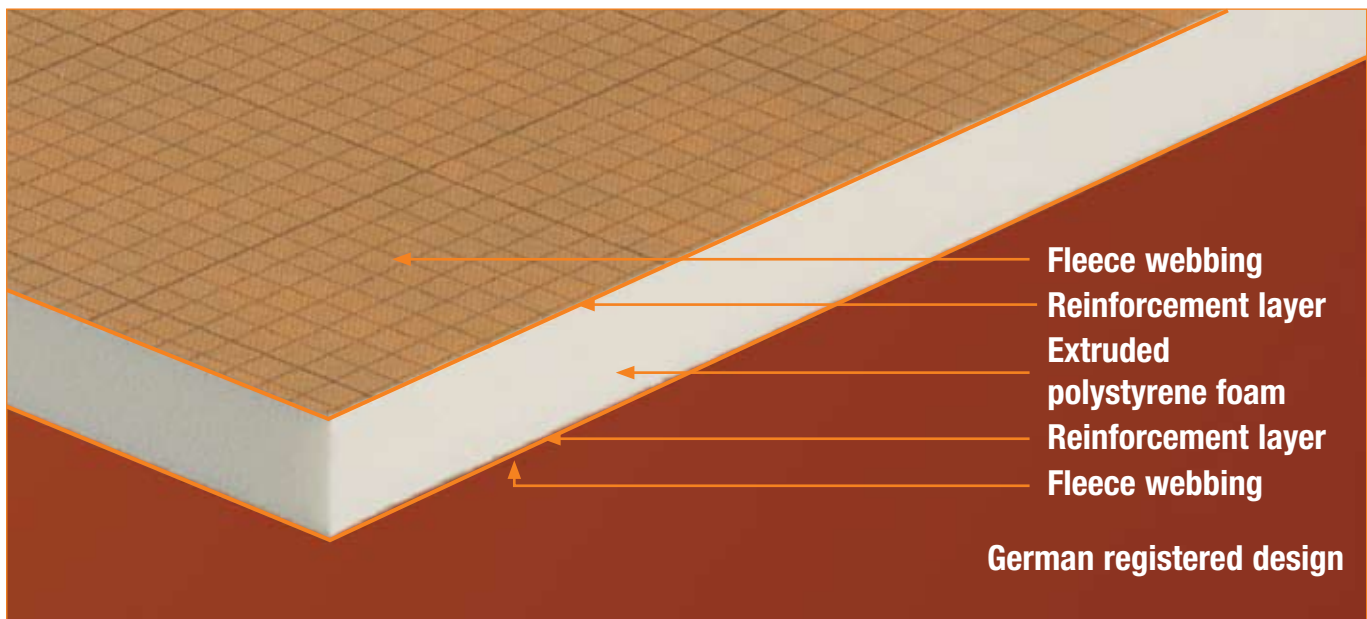
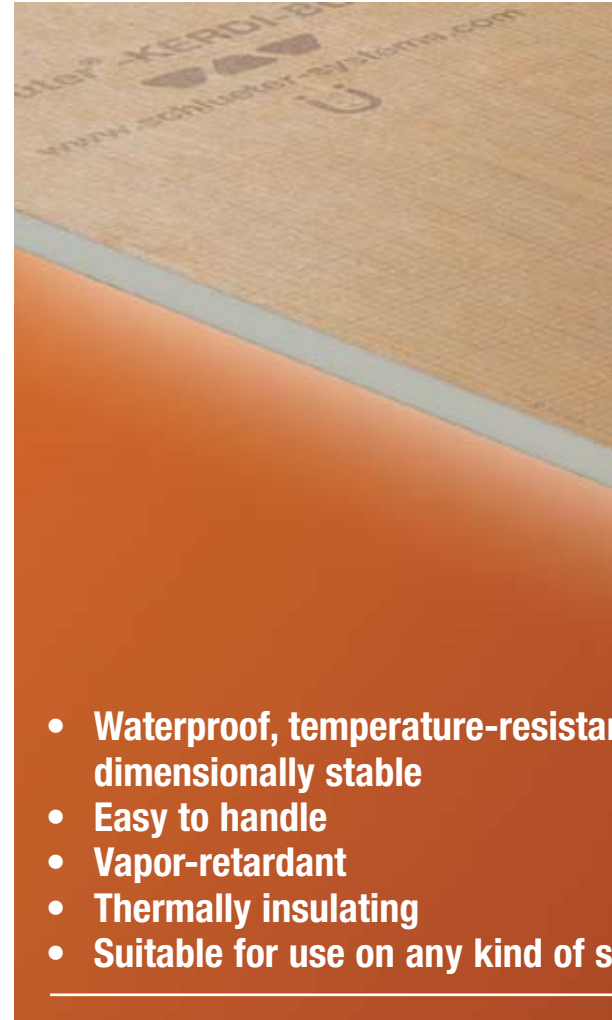

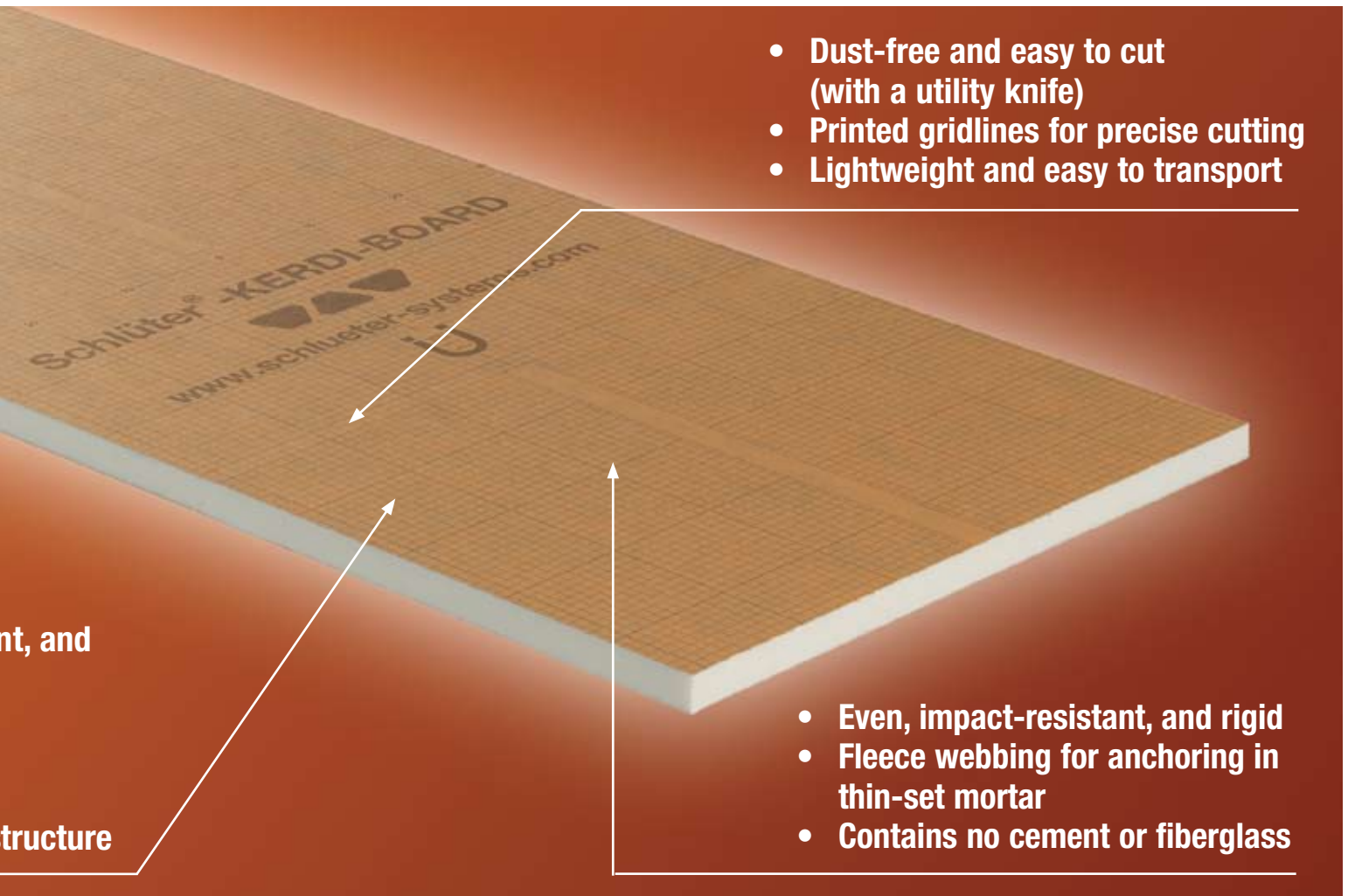

- Dust-free and easy to cut (with a utility knife)
- Printed gridlines for precise cutting
- Lightweight and easy to transport

nt, and

structure

- Even, impact-resistant, and rigid
- Fleece webbing for anchoring in thin-set mortar
- Contains no cement or fiberglass



Note:

Many substrates encountered in new buildings and renovation projects are unsuitable for tile installation, especially in areas with high moisture. This can require comprehensive preparation and waterproofing measures. Schlüter®-KERDI-BOARD makes it easy to create an ideal substrate for tile installation over existing structures as diverse as masonry, wood or metal framing, and mixed/existing substrates in renovation projects. The following pages explain a variety of individual application areas in greater detail.

Schluter®-KERDI-BOARD

Ideal tile substrate over masonry or existing/mixed substrates

Uneven substrates

Installing tiles using the thin-set method requires substrates to be clean and even. Masonry walls and existing/mixed substrates are often unsuitable substrates for direct application of tile because they can be uneven or difficult to bond to.

Schluter®-KERDI-BOARD is ideal for installation on:

- Concrete
- Masonry of all kinds
- Existing substrates such as plaster, tiles, painted surfaces, etc.
- Mixed substrates

Depending on the condition of the existing wall areas, KERDI-BOARD can be either fully embedded in thin-set mortar or spot-bonded. Spot-bonding the panels with thin-set mortar allows for adjustment to achieve plumb wall surfaces.

Schluter®-KERDI-BOARD can be installed vertically as well as horizontally. Where wall surfaces will not accept a bond to thin-set mortar, KERDI-BOARD can be further attached with the help of the special anchors included in our hardware assortment.

Tiles can be installed over Schluter®-KERDI-BOARD with thin-set mortar immediately; no additional prep is required.

Schluter®-KERDI-BOARD in bonded waterproofing assemblies

Schluter®-KERDI-BOARD is suitable for use in bonded waterproofing assemblies. For this purpose, the corners and joints must be sealed with Schluter®-KERDI-BAND using unmodified thin-set mortar. Fastener penetrations may be sealed with Schluter®-KERDI-BAND using unmodified thin-set mortar. Other protrusions through the KERDI-BOARD (e.g., showerhead, tub spout, etc.) must be treated with Schluter®-KERDI-SEAL-PS seals or Schluter®-KERDI-FIX.

Suitable panel thicknesses of Schluter®-KERDI-BOARD

If the substrate is sufficiently even to allow for fully embedding the panels in thin-set mortar, panel thicknesses from 3/16" (5 mm) can be selected. If the panels are to be spot-bonded, thicknesses of 3/8" (9 mm) or more are required, depending on specific project requirements.



Installation notes:
 The images shown in this brochure illustrate the essential installation steps. The text provides brief, summarized descriptions. For further details on the individual products and their installation, please refer to the corresponding product data sheets and installation handbooks.



Schluter®-KERDI-BOARD

Ideal tile substrate over stud frame structures

Wood or metal framing

Stud framing is typically covered with gypsum board. Often, the trades that hang the gypsum board do not take the time to ensure that the finished surfaces are plumb with square corners. Furthermore, gypsum board panels require additional prep, such as waterproofing, prior to setting tile in wet areas.

Schluter®-KERDI-BOARD is quick and easy to install as a substrate for tile coverings over wood or metal framing, using the screws and washers included in our hardware assortment. Panel joints are to be located on the studs or other solid backing. KERDI-BOARD can be installed vertically as well as horizontally.

Tiles can be installed with thin-set mortar immediately after the proper attachment of KERDI-BOARD; no additional prep is required.



Schluter®-KERDI-BOARD in bonded waterproofing assemblies

Schluter®-KERDI-BOARD is suitable for use in bonded waterproofing assemblies. For this purpose, the corners and joints must be sealed with Schluter®-KERDI-BAND using unmodified thin-set mortar. Fastener penetrations may be sealed with Schluter®-KERDI-BAND using unmodified thin-set mortar. Other protrusions through the KERDI-BOARD (e.g., showerhead, tub spout, etc.) must be treated with Schluter®-KERDI-SEAL-PS seals or Schluter®-KERDI-FIX.

for installation on wall framing with studs spaced at 24" (610 mm) o.c. is 3/4" (19 mm). The maximum recommended on-center fastener spacing is 12" (30.5 cm).



Installation notes:

The images shown in this brochure illustrate the essential installation steps. The text provides brief, summarized descriptions. For further details on the individual products and their installation, please refer to the corresponding product data sheets and installation handbooks.





Partition walls made with Schluter®-KERDI-BOARD

Ideal tile substrate

Sanitary installations frequently require partition walls to create separate shower or toilet stalls or to divide rooms. The construction of such walls using masonry blocks or stud framing with sheathing is time-consuming and often requires further preparation before tiling can begin.

Suitable panel thicknesses of Schluter®-KERDI-BOARD can be used to quickly and simply create stable and self-supporting partition walls for tiling. If required, the partition walls can be further attached or stabilized with the angled and U-shaped profiles, which form part of the complete system. The abutting seams and joints must be filled with thin-set mortar. Stainless steel profiles can be used to cover the visible areas.

Schluter®-KERDI-BOARD is ideally suited to create anything from simple partitions to entire toilet and shower facilities or public changing rooms.



Suitable panel thicknesses of Schluter®-KERDI-BOARD

Depending on project requirements, panel thicknesses of 2" (50 mm) should be used for self-supporting partition walls.



Installation notes:

The images shown in this brochure illustrate the essential installation steps. The text provides brief, summarized descriptions. For further details on the individual products and their installation, please refer to the corresponding product data sheets and installation handbooks.



Showers and bathtub surrounds made with Schluter®-KERDI-BOARD

Ideal tile substrate

Tiled showers and bathtub surrounds require proper moisture management to ensure successful long-term performance. While cement backerboards are moisture-resistant, they are not waterproof. Thus, additional measures must be taken to protect wall cavities from water and vapor penetration.

In addition to being lightweight and easy to cut with a utility knife, Schluter®-KERDI-BOARD is inherently waterproof and vapor-retardant. When used in conjunction with the Schluter®-Shower System, KERDI-BOARD provides an integrated tile backing and moisture management system for tiled showers and bathtub surrounds.

Schluter®-KERDI-BOARD in bonded waterproofing assemblies

Schluter®-KERDI-BOARD is suitable for use in bonded waterproofing assemblies. For this purpose, the corners and joints must be sealed with Schluter®-KERDI-BAND using unmodified thin-set mortar. Fastener penetrations may be sealed with Schluter®-KERDI-BAND using unmodified thin-set mortar. Other protrusions through the KERDI-BOARD (e.g., showerhead, tub spout, etc.) must be treated with Schluter®-KERDI-SEAL-PS seals or Schluter®-KERDI-FIX.





Bathtub platforms made of Schluter®-KERDI-BOARD

Ideal tile substrate

Bathtub platforms are excellent opportunities for tile coverings. However, tile setters are often faced with substandard framing, particularly on new construction projects. Many of the materials used to build the platforms are moisture-sensitive and require additional preparation prior to setting tile. Schluter®-KERDI-BOARD can be used to quickly and simply create flat, level, plumb, square, and waterproof tub platforms.

The grooved versions of the panel and the easy cutting properties of Schluter®-KERDI-BOARD also allow for effective use in creating curved surfaces.

Schluter®-KERDI-BOARD in bonded waterproofing assemblies

Schluter®-KERDI-BOARD is suitable for use in bonded waterproofing assemblies. For this purpose, the corners and joints must be sealed with Schluter®-KERDI-BAND, using unmodified thin-set mortar. Fastener penetrations may be sealed with Schluter®-KERDI-BAND using unmodified thin-set mortar.

Suitable panel thicknesses of Schluter®-KERDI-BOARD

Select the panel thickness according to the size and expected stresses of the project. 2" (50 mm)-thick panels are typically used as support members.



Installation notes:

The images shown in this brochure illustrate the essential installation steps. The text provides brief, summarized descriptions. For further details on the individual products and their installation, please refer to the corresponding product data sheets and installation handbooks.

Vanities and shelving made of Schluter®-KERDI-BOARD

Ideal tile substrate

Schluter®-KERDI-BOARD is the ideal substrate for constructing vanities and shelving with tile coverings. Using KERDI-BOARD as a building panel makes it possible to quickly and easily build the vanity structure with the technical and aesthetic requirements of the tile covering in mind.

KERDI-BOARD is dimensionally stable and waterproof. Panels and openings are easily cut with a utility knife.

The visible edges can be finished in a number of ways, including:

- Brushed stainless steel U-shaped profiles in combination with the Schluter®-RONDEC or Schluter®-QUADEC finishing profiles
- Schluter®-RONDEC-CT or Schluter®-RONDEC-STEP edge profiles
- Tile strips and two finishing profiles such as Schluter®-RONDEC or Schluter®-QUADEC



Suitable panel thicknesses of Schluter®-KERDI-BOARD

Select the panel thickness according to the size and expected stresses of the project. 2" (50 mm)-thick boards are suitable for building the structure, while 3/4" (19 mm)-thick boards can typically be used for shelving.



Installation notes:

The images shown in this brochure illustrate the essential installation steps. The text provides brief, summarized descriptions. For further details on the individual products and their installation, please refer to the corresponding product data sheets and installation handbooks.



Countertops made of Schlüter®-KERDI-BOARD

Ideal tile substrate

Tiled countertops are often constructed with plywood decks, which are dimensionally unstable and moisture-sensitive. Additional work is required to prepare the surface for tile installation, which can be time-consuming.

Schlüter®-KERDI-BOARD is particularly suitable for building countertops and other work surfaces with tile coverings. KERDI-BOARD is dimensionally stable and waterproof and can be adhered directly to base cabinets, thus eliminating the need for labor-intensive preparation. Panels and openings are easily cut with a utility knife.

The sink rail can be created in a number of ways, including:

- Brushed stainless steel U-shaped profiles in combination with the Schlüter®-RONDEC or Schlüter®-QUADEC finishing profiles
- Schlüter®-RONDEC-CT or Schlüter®-RONDEC-STEP edge profiles
- Tile strips and two finishing profiles such as Schlüter®-RONDEC or Schlüter®-QUADEC

Suitable panel thicknesses of Schlüter®-KERDI-BOARD

Panel thicknesses of 1-1/2" (38 mm) or 2" (50 mm) are recommended when adhering KERDI-BOARD directly to base cabinets.





Pipe and column coverings made of Schluter®-KERDI-BOARD

Ideal tile substrate

The innovative, prefabricated L-shaped and U-shaped panels of the Schluter®-KERDI-BOARD system make it especially easy to conceal pipes and columns.

The panels feature V-shaped grooves and are shipped in a space-saving flat design, which makes them easy to store. The flat panels are also quick to cut to the necessary dimensions. Thin-set mortar, Schluter®-KERDI-FIX, or double-sided adhesive tape is applied to the V-grooves. Fold the panels prior to installation.



Installation notes:

The images shown in this brochure illustrate the essential installation steps. The text provides brief, summarized descriptions. For further details on the individual products and their installation, please refer to the corresponding product data sheets and installation handbooks.





Curved wall areas, columns, and fixtures constructed of Schluter®-KERDI-BOARD-V

Ideal tile substrate

The grooved version of the Schluter®-KERDI-BOARD panel is designed for creating rounded and curved elements.

The panel allows for quick and easy creation of:

- Self-supporting partition walls (e.g., for multiple shower cubicles)
- Tub surrounds
- Coverings for support structures and columns
- Coverings for pipes and duct work
- Wall coverings

If the grooved surface points toward the inside, it is recommended that the grooves be filled with thin-set mortar prior to installation.

If a larger expanse of panels is required, several panels can be connected along the edges with thin-set mortar, Schluter®-KERDI-FIX adhesive, or double-sided adhesive tape.



Installation notes:

The images shown in this brochure illustrate the essential installation steps. The text provides brief, summarized descriptions. For further details on the individual products and their installation, please refer to the corresponding product data sheets and installation handbooks.



Schluter®-KERDI-BOARD		
Length	Width	Thickness
64" (162.5 cm)	48" (122 cm)	3/16", 3/8", 1/2" (5, 9, 12.5 mm)
96" (244 cm)	48" (122 cm)	3/16", 3/8", 1/2" (5, 9, 12.5 mm)
96" (244 cm)	24-1/2" (62.5 cm)	3/4", 1", 1-1/2", 2" (19, 25, 38, 50 mm)

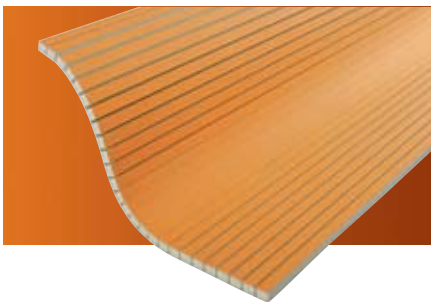

Schluter®-KERDI-BOARD-V



Schluter®-KERDI-BOARD-E

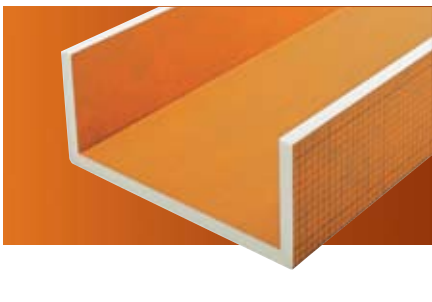

Schluter®-KERDI-BOARD-U





Accessories

- ① U-shaped brushed stainless steel profile with closed anchoring leg on the underside for finishing countertops or similar structures.
- ② U-shaped brushed stainless steel profile for visible edges of partition walls and shelves.
- ③ A flat plastic profile can be attached behind the U-shaped profile for secure attachment of finishing hardware.
- ④ Three-sided, perforated U-shaped stainless steel profile to reinforce open-ended partition walls.
- ⑤ To enhance stability, the three-sided, perforated U-shaped profile or angle profile can be integrated into the joints of a freestanding partition.
- ⑥ Stainless steel angle profile as an aligned attachment stop.
- ⑦ Attachment stops can also be created with 6" (15 cm) angle pieces.
- ⑧ Quick installation screws and washers for attaching KERDI-BOARD to stud framing.
- ⑨ Anchors for additional mechanical attachment of KERDI-BOARD to difficult-to-bond-to substrates.
- ⑩ Double-sided adhesive tape for connecting KERDI-BOARD panels at abutting joints and similar places.

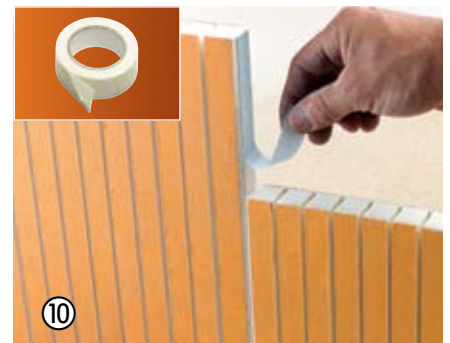
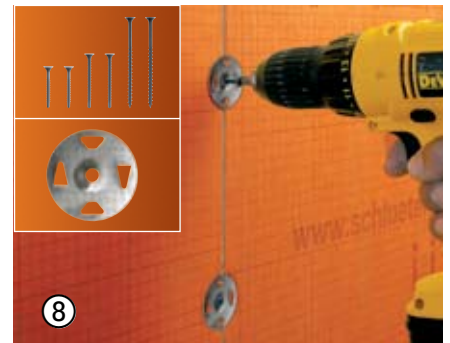
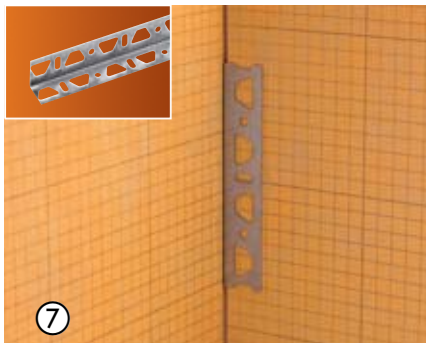
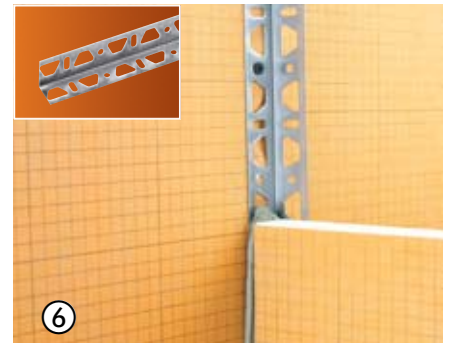
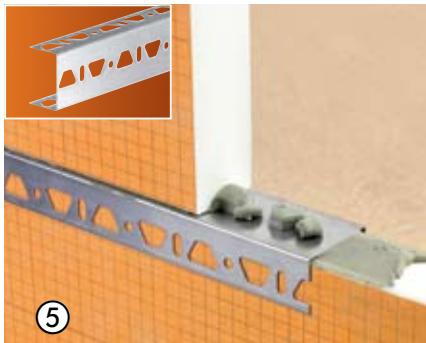
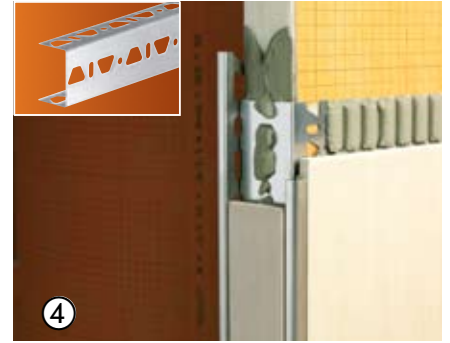
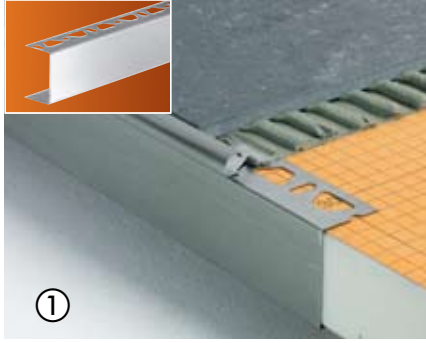



For further details and installation instructions, please refer to our product data sheet or visit our website at www.schluter.com.



PROFILE OF INNOVATION

Schluter Systems L.P. 194 Pleasant Ridge Road, Plattsburgh, NY 12901-5841 Tel.: 1-800-472-4588 Fax: 1-800-477-9783 e-mail: info@schluter.com	Schluter Systems (Canada) 21100 Chemin Ste-Marie, Ste-Anne-de-Bellevue, QC, H9X 3Y8 Tel.: 1-800-667-8746 Fax: 1-877-667-2410 e-mail: info@schluter.com
---	---

www.schluter.com